

ISUZU

SPECIFICATIONS

NPS 75/45-155 4X4

NPS 75/45-155 4X4 CREW

Now
available
with AMT



Indicative image only

AUSTRALIA'S TOP SELLING TRUCK BRAND SINCE 1989.

AT A GLANCE

GVM	7,500 kg / 4,500 kg
GCM	11,000 kg / 8,000 kg
Power	114 kW @ 2,600 rpm
Torque	419 Nm @ 1,600 - 2,600 rpm

UPGRADE OPTIONS

AMT Pack: Automated Manual Transmission (AMT)

ADVANCED TECHNOLOGY

Emissions: Euro V / ADR 80/03
Driver and passenger airbag with seatbelt pretensioner
ECE-R29 compliant cab
Anti-lock Braking System (ABS)
Hill Start Aid (HSA) - except AMT pack
Electric control switches for High/Low range and 4WD engagement

Wide 850 mm frame with parallel rails and rivetless top flange

Electric mirrors

Cruise control

Front stabiliser bar

Driver suspension seat - single cab only

Cornering lamps



ISUZU

RELIABILITY IS EVERYTHING

NPS 75/45-155 4X4

NPS 75/45-155 4X4 CREW

DRIVELINE AND CHASSIS SPECIFICATIONS

ENGINE: ISUZU 4HK1-TCN

- Type:** 4 cylinder 16 valve SOHC
Displacement: 5,193 cc
Compression ratio: 17.5:1
Bore x Stroke: 115 mm x 125 mm
Max power (DIN-NET): 114 kW (153 HP) @ 2,600 RPM
(JIS Gross): 118 kW (158 HP) @ 2,600 RPM
Max torque* (DIN-NET): 419 Nm (309 lb.ft) @ 1,600 - 2,600 RPM
(JIS Gross): 434 Nm (320 lb.ft) @ 1,600 - 2,600 RPM
Induction system: Electronically controlled variable nozzle turbocharger with air-to-air intercooler.
Fuel injection: Direct injection high pressure common rail system.
Emission control system: Cooled EGR with exhaust Diesel Oxidation Catalyst (DOC). ADR 80/03 (Euro V) compliant.
* Maximum torque electronically limited to 377 Nm (DIN) when in low range first or reverse gear

CLUTCH

- Standard model:** Auto adjusting hydraulic control with vacuum assistance. Single plate 325mm diameter.
• Total lining area: 966cm².
AMT pack: Fully automated hydraulically controlled wet clutch and fluid coupling with lock up.

TRANSMISSION

Standard model: ISUZU MYY-5A

- 5 speed manual. Synchromesh on gears 1-5.
 - PTO provision on LHS of transmission case. PTO drive from counter gear.
 - Gear ratios (: 1)
- | 1st | 2nd | 3rd | 4th | 5th | Rev |
|-------|-------|-------|-------|-------|-------|
| 5.315 | 2.908 | 1.558 | 1.000 | 0.721 | 5.068 |

AMT Pack: ISUZU MYY-5A

- 5 speed Automated Manual Transmission (AMT) with both fully automatic and clutchless manual operation modes.
 - PTO provision on LHS of transmission case. PTO drive from counter gear.
 - Gear ratios (: 1)
- | 1st | 2nd | 3rd | 4th | 5th | Rev |
|-------|-------|-------|-------|-------|-------|
| 5.315 | 2.908 | 1.558 | 1.000 | 0.721 | 5.068 |

TRANSFER GEARBOX:

- Part time 4WD.
- High ratio 1.00:1, Low ratio 1.842:1

AXLES

Front: Isuzu FD031

- Full floating Banjo type. Birfield outer joints and manual lock front hubs. 3,100 kg capacity.
- Drive ratio 5.571:1

Rear: Isuzu R066

- Full floating Banjo type. Four pinion limited slip differential. 6,600 kg capacity.
- Drive ratio: 5.571:1

SUSPENSION

Front:

- Single stage alloy steel multi-leaf springs.
- Double acting hydraulic shock absorbers. Stabiliser bar.

Rear:

- Multi-leaf main spring, multi-leaf helper spring.
- Double acting hydraulic shock absorbers.

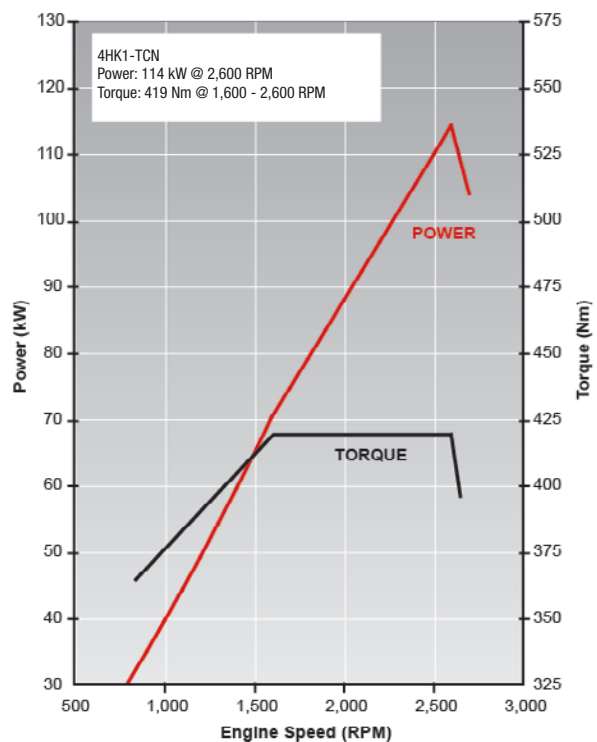

BRAKES

- Front and rear drum brakes with dual circuit hydraulic control, hydraulic pressure assistance and load sensing proportioning valve.
- Front drum size: 320 x 100 mm
- Rear drum size: 320 x 100 mm
- ABS. Active in high range gear selection mode.
- Hill Start Aid (HSA) - except AMT pack.
- 190 mm diameter drum park brake mounted on rear of transmission.
- Vacuum controlled exhaust brake.

STEERING

- Power assisted recirculating ball steering.
- Gear ratio: 20.9:1
- Turns lock to lock: 3.7
- Maximum angle: 38° (inside wheel) / 30° (outside wheel)

WHEELS AND TYRES

- 17.5 x 6.00 six stud steel wheels.
- 225/80R17.5 123/122L Bridgestone L330 Tubeless.
- Maximum tyre rating:
 - Front axle: 3,100 kg
 - Rear axle: 6,000 kg
- 1 frame mounted spare wheel and tyre assembly.

CHASSIS FRAME

- Cold rivetted ladder frame. SAPH440 weldable steel sidemembers. Parallel side rails and rivetless top flange.
- Frame dimensions:
 - Side rail (mm): 216 x 70 x 6.0
 - Rear frame width (mm): 850

FUEL TANK

- Frame mounted 140L steel fuel tank.
- Lockable fuel cap.

ELECTRICAL SYSTEM

- 24 volt electrical system.
- 90 amp alternator.
- 4.5 kW starter motor.
- 2 x 80D26L (630 CCA) batteries connected in series.

CABIN SPECIFICATIONS AND APPOINTMENTS

CAB EXTERIOR

- All steel construction. High tensile steel used for cab underframe.
Single cab: Manual cab tilt to 45° with torsion bar assistance.
- Complies with ECE-R29 cab strength standard.
- **Single cab:** Liquid filled front and rear cab mounts.
Crew cab: Rubber cab mounts.
- Heavy duty non slip entry steps.
- 90° opening internally reinforced front doors.
- Water spray suppression guards and front mudflaps.
- Laminated windscreen with shade band.
- Two speed windscreen wipers with intermittent wipe mode.
- Halogen multi-reflector headlamps incorporating turn signals. Additional door mounted integrated side indicator/cornering lamps.
- Combination brake, turn, reverse and marker lamps, registration plate illumination lamps. Extended wiring harness. Reverse alarm.
- Roof-mounted clearance lamps.
- Heated and powered exterior main mirrors with flat glass and additional independantly adjustable convex "spot" mirrors.
- Body coloured grille.
- Body coloured impact resisting polycarbonate bumper with steel backing frame.

CAB INTERIOR

- Contoured adjustable driver's bucket seat. **Single cab:** includes mechanical suspension rated to 130kg.
- Front passenger bench seat with 2 seat capacity.
- **Crew cab:** Engine access provided under removable driver seat base and tiltable front passenger seat.
- **Crew cab:** Rear bench seat with 4 seat capacity.
- 3-point lap sash seatbelts in all outboard seating positions. Driver and outboard front passenger seatbelts fitted with pretensioner. Centre seat lap belts.
- Driver and outboard front passenger airbag.
- **AMT Pack:** Driver's footrest
- Door and roof pillar entry assist grips. **Crew cab:** Full width rear grab rail with ashtray.
- Full interior trim, padded roof lining and vinyl floor covering. Driver and passenger windscreen header storage shelf.
- Tilt/Telescopic adjustable steering column, soft feel urethane steering wheel.
- Electric windows.
- Central locking with remote keyless entry and immobiliser.
- Twin cup holders. 24V cigarette lighter. Dashboard hook.
- Front door mounted storage pockets and driver's side ashtray.
- Centre console box with storage tray. Fold down storage tray behind centre seat backrest
- Fully integrated air conditioning and heater/demister with 4-speed fan and outlets for windscreen, side windows, face and floor.
- Interior lamp with On/Door/Off switch. **Single cab:** fluorescent type.
Crew cab: standard type.

- 2 DIN, two speaker multimedia unit with 6.2" LCD capacitive touch screen. 1.6GHz processor with Android operating system. DAB+ digital radio and fully integrated Bluetooth with voice recognition. Inbuilt PDF, photo and movie viewer. Internet radio accessible via smartphone. 32GB internal file storage. USB and auxilliary input connection provisions.
- DIN sized compartment for storage or for CB radio installation.

DRIVER CONTROLS

- Key-operated engine start/stop and steering lock. Engine idle speed control.
- HSA slow/fast engagement control and on/off switch - except AMT pack.
- **AMT Pack:** AMT slow/fast gear engagement control, 1st gear start and normal/economy gear selection modes.
- High/Low range and 4WD engage switches.
- **AMT Pack:** Gear selection control with R-N-D and sequential shift positions.
- **Left side combination stalk:** Windscreen wipers, washers and exhaust brake.
- **Right side combination stalk:** Turn signals, headlamps, cruise control.

INSTRUMENTATION

- Electronically driven speedometer and tachometer. Digital odometer with integrated dual tripmeter. Engine coolant temperature and fuel level gauges.
- **Warning lamps:** Check engine, oil pressure, ABS, SRS airbag, alternator charge, service brakes, park brake, seatbelt unfastened, low fuel level.
AMT pack: Check AMT.
- **Indicator lamps:** HSA (except AMT pack), warm up system, high beam, exhaust brake, low range engaged, 4WD engaged, turn signals.
- **Multi information display:** Shows service interval, instantaneous and average fuel consumption hourmeter, voltmeter, time/day/date and includes 40-120km/h adjustable vehicle speed warning.

OPTIONS AND GENUINE ACCESSORIES

Include the following (extra cost, request a brochure and further details from your Isuzu dealer):

Multimedia unit:

- Telematics system.
- Isuzu satellite navigation including 3 years of free updates.
- Supports up to five camera inputs. One digital camera with infrared and rear microphone input active when reversing, four analogue cameras.
- Reversing sensors.
- Tyre pressure monitoring system.
- Blind spot viewing cameras.
- ADAS (Advanced Driver Assistance System). Includes lane departure warning, forward collision warning and pedestrian collision alert.
- Wireless inductive phone charger.

Other:

- Airbag compatible bullbar.
- 3,500kg rated towbar.
- Air deflector.

ISUZU CARE

Isuzu Care gives truck owners access to products and services including Roadside Assist, Service Agreements, Extended Care, Extended Isuzu Assist and the Isuzu Care Centre. Call 1800 035 640.

WEIGHTS (kg)

Models	Ratings*		Loading Limit* (at ground)		Cab Chassis Weight #		
	GVM	GCM	Front	Rear	Front	Rear	Total
NPS 75/45-155 4x4	7,500 / 4,500	11,000 / 8,000	3,100	6,000	1,960	970	2,930
NPS 75/45-155 AMT 4x4	7,500 / 4,500	11,000 / 8,000	3,100	6,000	1,980	970	2,950
NPS 75/45-155 4x4 CREW	7,500 / 4,500	11,000 / 8,000	3,100	6,000	2,100	1,070	3,170
NPS 75/45-155 AMT 4x4 CREW	7,500 / 4,500	11,000 / 8,000	3,100	6,000	2,120	1,070	3,190

* Vehicle ratings and front/rear weight limits are subject to government regulatory requirements and weight distribution analysis. Consult your Isuzu dealer to select the correct vehicle for your specific application. # Cab chassis only as supplied and including 10 litres of fuel.

DIMENSIONS (mm)

Models	WB	OAL	FOH	ROH	EA	CE	RT	ORT	CH	FFA (unladen)	RFA (unladen)	RFH (unladen)	Turn Circle (m)
													KERB TO KERB
NPS 75/45-155 4x4	3,395	5,985	1,080	1,510	2,710	4,332	1,650	2,120	2,490	850	940	975	13.6
NPS 75/45-155 4x4 CREW	3,395	5,985	1,080	1,510	1,730	3,331	1,650	2,120	2,490	850	950	980	13.6

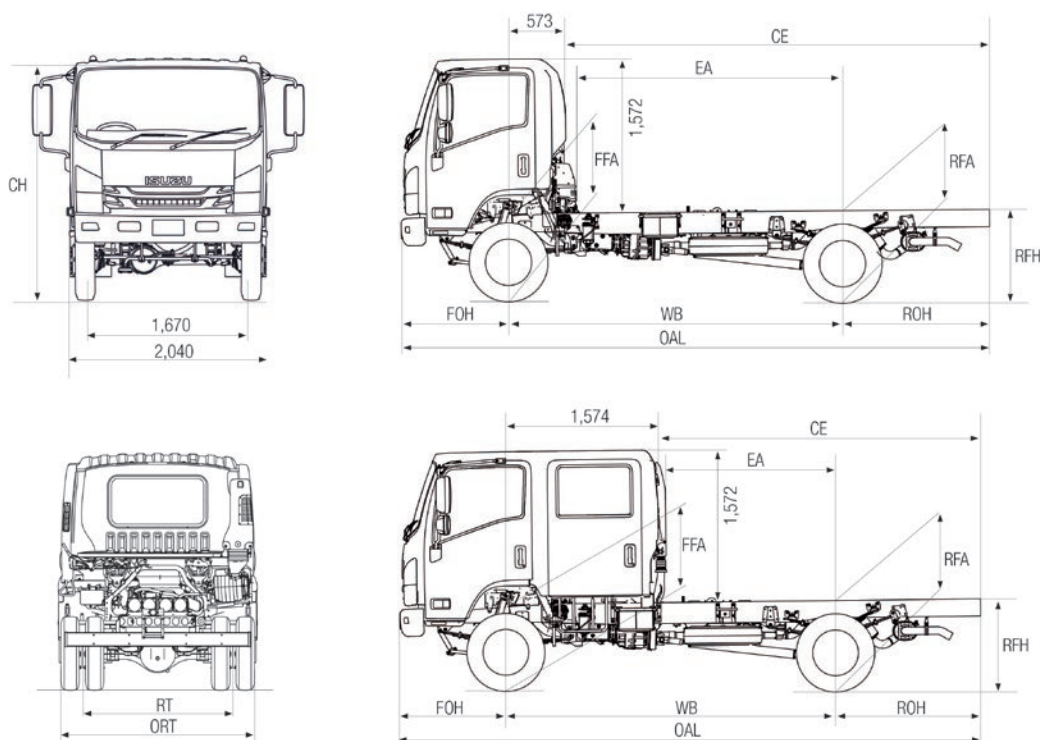

PERFORMANCE (calculated - typical paved road)

	Geared Speed* (top gear at peak power engine RPM)	Low Speed Gradeability (lowest forward gear assuming no wheel slip)	Engine Speed (top gear at 100km/h)	
NPS 45-155 4x4	At 4,500 kg GVM	95 km/h @ 2,600 RPM	> 100%	2,725 RPM
NPS 75-155 4x4	At 7,500 kg GVM	95 km/h @ 2,600 RPM	62%	2,725 RPM

*Maximum speed achievable depends on vehicle frontal area as well as other factors. Consult your Isuzu dealer for more detailed information.

ISUZU WARRANTIES

STANDARD ¹	
New Vehicle	3 years • 100,000km • 2,000 hours
Cab Perforation Corrosion	3 years • Unlimited km
Isuzu Assist: 24 hour roadside assistance (3 years, unlimited km)*	
EXTENDED CARE ²	
On application only	

ORDER CODES

Model	Code
NPS 75/45-155 4x4	NH-NPSAB-B18
NPS 75/45-155 AMT 4x4	NH-NPSAB-D18
NPS 75/45-155 4x4 CREW	NH-NPSDB-B18
NPS 75/45-155 AMT 4x4 CREW	NH-NPSDB-D18

¹ Subject to the conditions outlined in the IAL New Vehicle Warranty, the Isuzu NPS models carry a standard factory warranty which covers the owner: (i) for the entire vehicle, for the first 36 months or 100,000 km or 2,000 hrs (whichever comes first), (ii) against cab perforation corrosion, for 36 months and unlimited kilometres. ² Extended Warranty as illustrated may be purchased to cover the owner against the failure of original components, but may exclude some components and expendable items such as oil, filters, etc. *Valid for three years from the date of new vehicle purchases. All Isuzu warranties are subject to mandatory prescribed terms under Australian Consumer law including customer guarantees. For more details visit the Isuzu website which explains Isuzu warranties in more detail, or alternatively contact your local dealer. All warranties commence from date of delivery.

ISUZU AUSTRALIA LIMITED ABN 97 006 962 572 ("IAL"). The information in this spec sheet was correct at time of printing, but all measurements, specifications and equipment are subject to change without notice. Some equipment may have been changed and/or is available at extra cost. IAL may make changes at any time without notice, in prices, colours, materials, equipment and models. IAL makes all reasonable attempts to ensure the availability of all vehicles and equipment. The information in this spec sheet is general in nature. Your Isuzu dealer can confirm all measurements, specifications and vehicle / equipment availability upon request. To the extent permitted by the law, IAL is not liable to any person as result of reliance on the content of this spec sheet.

ISUZU
RELIABILITY IS EVERYTHING